

Using Power Quality Data for Capacitor Bank Health Assessment and Failure Prevention

By Theo Laughner and Anthony Murphy

The Tennessee Valley Authority (TVA) provides electricity for approximately 9 million people in the southeastern region of the United States. TVA is committed to providing safe, clean, reliable, and affordable electric power to homes and businesses within the valley. Since low rates and reliability are priorities for TVA, it is imperative to get the full lifespan of equipment while reducing unplanned outages.

TVA has experienced instances of capacitor banks failing catastrophically and cases of capacitor banks requiring excessive corrective maintenance. In September of 2014, a cross-organizational team was commissioned to evaluate reactive resources on the TVA system. The team placed special focus on capacitor banks and identified the capacitor banks with the highest corrective maintenance expenses. As a pilot, the team field installed Power Quality Monitors (PQMs) on these problematic capacitor banks to see what useful data may be collected for troubleshooting.

The PQMs were used to monitor the three phase voltages from the station bus PTs and the three phase currents from the CTs in the capacitor bank breaker. In some cases, the PQMs also monitored the control voltages to the capacitor bank protective relay. TVA commonly has one or more capacitor banks served from a capacitor bus which is protected by a single capacitor bank breaker. Each capacitor bank is then switched by a dedicated circuit switcher which utilizes pre-insertion inductors for switching transient mitigation. Figure 1 illustrates a typical PQM installation. By utilizing the voltage and current signals from the existing PTs, CTs, and controls, the PQM could easily and affordably be retrofitted into the existing capacitor bank panel in the control room.

The data collected from the PQM could be used to analyze traditional power quality issues like harmonic resonance and overvoltage switching transients but also proved to be useful in identifying the following capacitor bank health issues:

- shorted elements in individual capacitor units
- effects of system voltage imbalance on capacitor unbalance protection
- failures of elements (capacitors, resistors...) in the low voltage control circuitry
- timing of circuit switchers and breakers
- alignment issues with circuit switcher including arcing horn and pre-insertion inductors
- breaker and circuit switcher restrikes

Figure 1

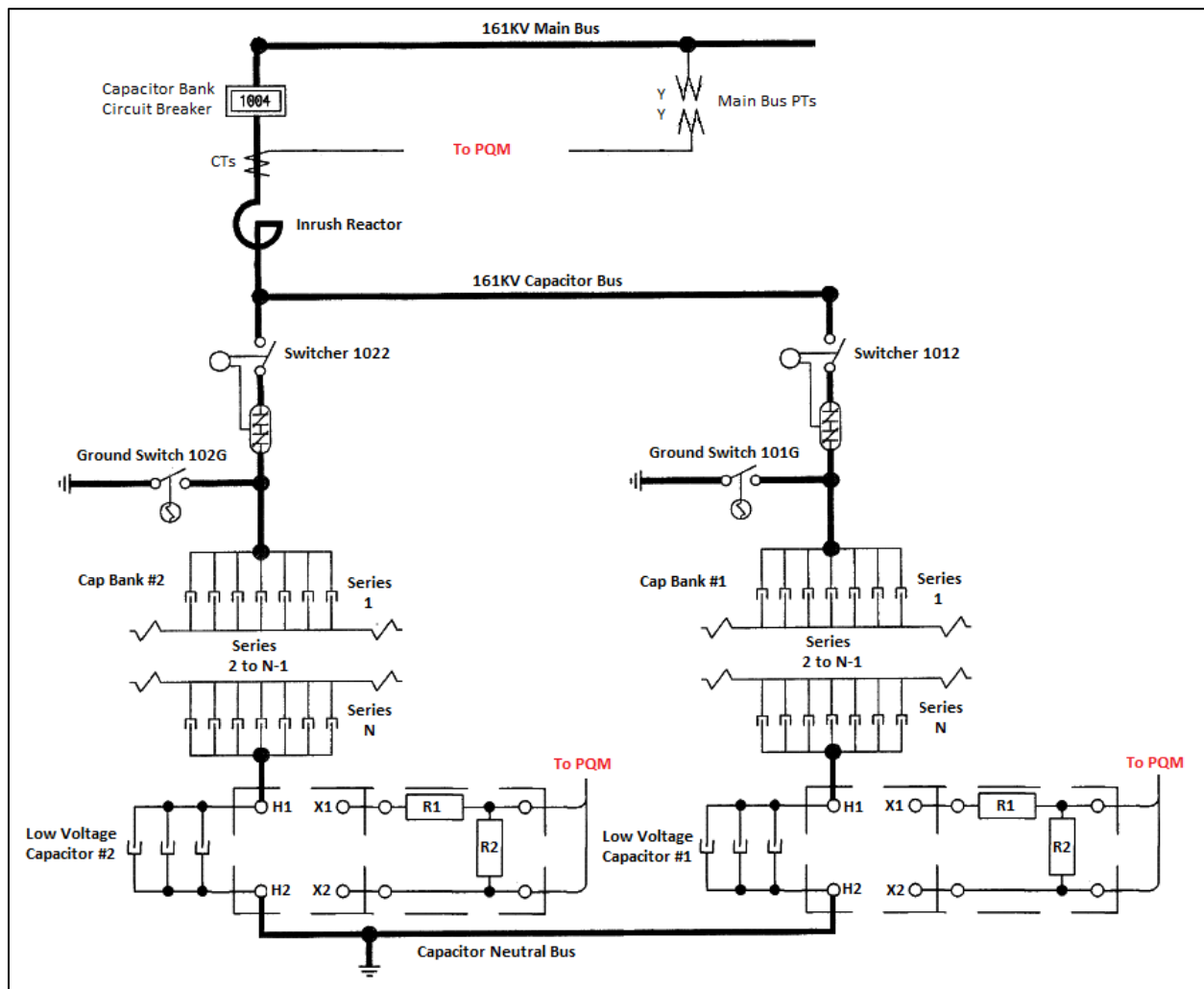

Note: Older designs include control elements in the common neutral only. Newer designs include control elements at the neutral terminal in each of the three phases separately.

The largest capacitor banks on the TVA 161kV system are comprised of up to 420 capacitor units each having up to four internal elements. Troubleshooting these large capacitor banks when they trip offline due to an unbalance alarm can be time consuming. Sometimes the unbalance alarm may not even be due to shorted capacitor elements but other conditions such as system voltage unbalance or failure to properly match capacitor unit tolerances between phases. The data collected from the PQMs allowed for verification of whether a shorted capacitor element had occurred. This prevented unnecessary and labor intensive troubleshooting. In cases where there actually had been a shorted capacitor element, the phase of the failed capacitor unit was readily identified. This reduced the work involved in troubleshooting by a third.

Figure 2 illustrates a case where a capacitor bank tripped offline a few hours after energization due to the unbalance protection. The unbalance protection was configured to trip upon the fourth shorted element. After reviewing the data from the PQM, it was determined that an element in B-phase had

indeed shorted just prior to the capacitor bank trip; however, the data also indicated that this was only the second shorted element in B-phase and there were no shorted elements in the other two phases. The remainder of the unbalance was attributable to the system voltage unbalance for which the protection relay was not compensated. The system voltage unbalance was of sufficient level that it placed the unbalance protection above the alarm limit resulting in continuous alarming. This also only allowed enough margin for two element failures (instead of four) before the unbalance protection would trip the capacitor bank. Waveform data recorded by the PQM proved very beneficial in making this detail of determination.

Figure 2

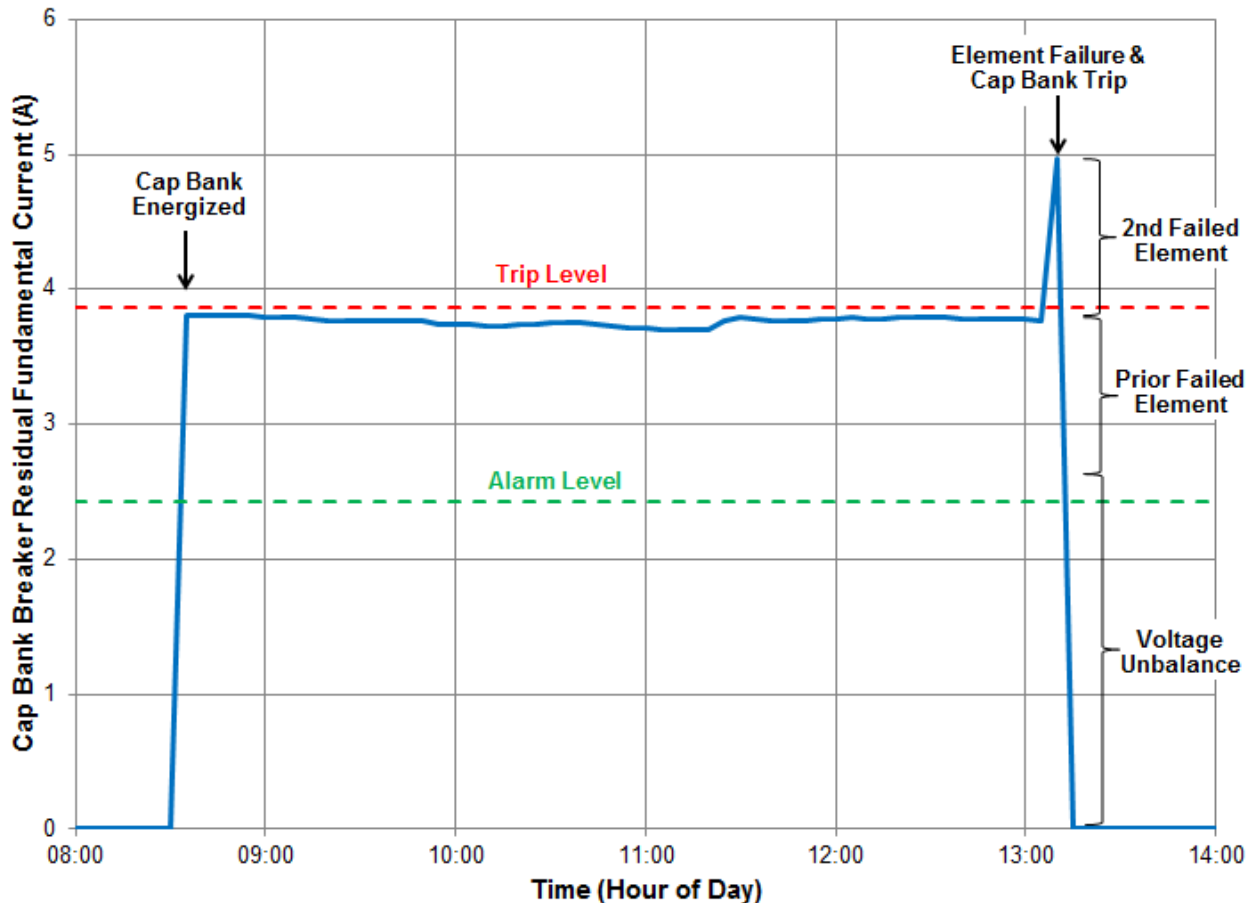

TVA has experienced cases of catastrophic failure of capacitor banks. The cost to replace such a failed capacitor bank has been over \$300,000. In such cases, the unbalance protection had effectively been disabled due to a failure of a capacitor or resistor (as shown in Figure 3) in the low voltage protection circuit. At some later time, the capacitor units would also fail. In the absence of effective unbalance protection, the remaining good capacitor units would be subjected to increasing levels of overvoltage leading to a cascading failure and eventual bus fault. The PQM can also monitor the control voltage at the back of the relay. Analysis of this data may be automated and notifications sent should the control voltage be lost before a catastrophic failure occurs.

Figure 3



The same data recorded by the PQM can also be used to assess issues with the breaker and circuit switchers used to operate the capacitor banks. Each time a breaker or switcher is opened or closed the PQM will trigger a waveform event. From this waveform data, the timing of the device may be determined and compared against historical operations in order to alert any changes. Alignment issues with the switcher mechanism can also be determined. TVA has experienced instances where the pre-insertion inductors were never contacted during the closing sequence which led to higher than expected transient overvoltages during capacitor energization. The PQMs record these transient overvoltage waveforms from which automated analysis can be made and notifications sent. Figure 4 shows a switcher where the set bolt had come out allowing the B-phase arcing horn to rotate out of alignment. Multiple PQMs had recorded the excessive transient overvoltage on B-phase.

Figure 4



Since the PQMs record a waveform each time the switcher or breaker is opened, alerts for restrikes can also be made. Figure 5 shows an example restrike waveform recorded by a PQM. A subsequent investigation found an alignment issue with the capacitor switcher which had led to arcing and pitting along the arcing horn as shown in Figure 6.

Figure 5

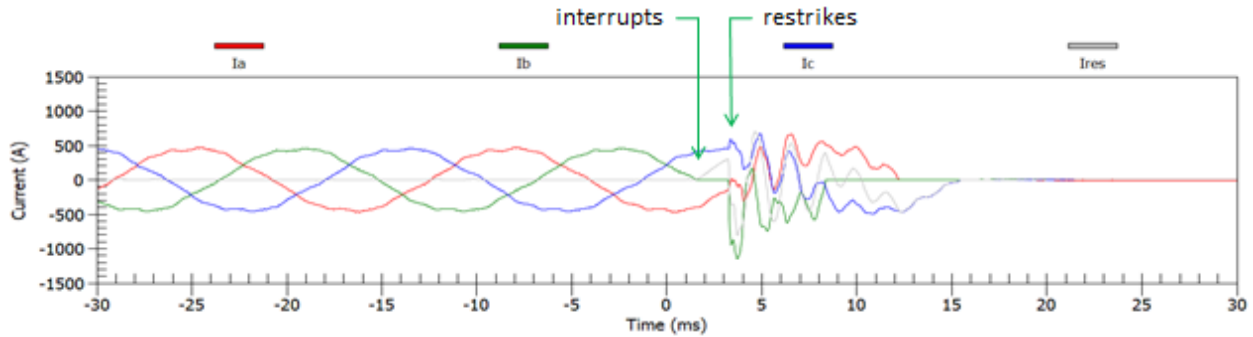
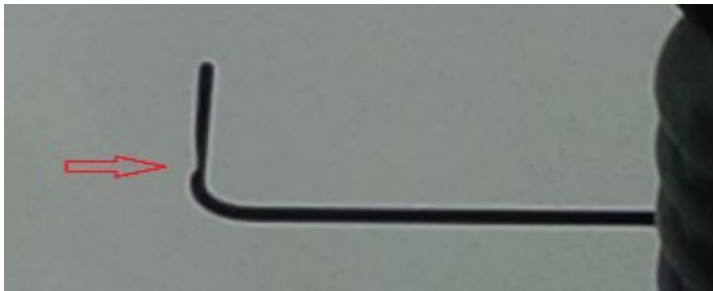

Figure 6



In conclusion, TVA has found that using PQMs to monitor capacitor banks is an effective and low-cost means to perform asset health assessments, prevent catastrophic failure, and reduce corrective maintenance expenses. This in turn improves reliability and helps to keep rates low for the customers of the Tennessee Valley.

Biographies

Anthony Murphy has been employed with the Tennessee Valley Authority for 18 years and has worked in both the customer service and transmission power quality groups. He currently serves as Power Quality Specialist for TVA. He holds a Bachelor of Science in Electrical Engineering degree from the University of Tennessee at Knoxville. He is a licensed Professional Engineer and a member of IEEE. He lives in Cleveland, TN with his wife, Leanna, and their four children, Hannah, Elliot, Hudson, and Lillian.

Theo L. Laughner is the Senior Program Manager of Power Quality at TVA. He is responsible for setting the direction of the power quality program at TVA and serves as a focal point for resolving power quality issues throughout TVA's system. During his tenure in the PQ program at TVA, he has focused on integrating data from over 1500 power quality monitors, digital fault recorders, revenue meters, and microprocessor relays into an enterprise database system.

Theo received a Bachelor's Degree in Engineering from University of Tennessee at Chattanooga. He is a professional engineer in the state of Tennessee. Theo is the chair of IEEE SCC 22 (Power Quality), the Chair of IEEE 1250 (Voltage Quality Working Group) and servers as the UNSC Representative to CIGRE for WG C4. He lives in Harrison, TN with his wife, Holly, and their four kids, John, Hannah, Cote and Zane.