

# Use of the “Electronic Current Transformer (ECT)” to Facilitate NERCs PRC-002 Reliability Standard

Don Burkart

Consolidated Edison of New York  
New York, NY 10003  
burkartd@coned.com

**Abstract**— This paper describes the use of the Electronic Current Transformer (ECT) sensors as a means to comply with the Regional Reliability Standard PRC-002-NPCC-Disturbance Monitoring by non-intrusively monitoring all required analog quantities. The Regional Reliability Standard imposed by the North American Electric Reliability Corporation (NERC) requires that adequate disturbance data is available to facilitate Bulk Electric System (BES) event analyses. The standard requires that Transmission and Generation Owners install Digital Fault (DFR) recording devices to provide extensive monitoring capabilities.

**Index Terms**—Current Transformer, Electronic Current Transformer, Disturbance Monitoring Equipment (DME), Digital Fault Recorder, Hall-Effect Sensor

## I. BACKGROUND

On August 14, 2003, just after 4:00 p.m. Eastern Daylight Time (EDT), the North American power grid experienced its largest blackout ever. The blackout affected an estimated 50 million people and more than 70,000 megawatts (MW) of electrical load in parts of Ohio, Michigan, New York, Pennsylvania, New Jersey, Connecticut, Massachusetts, Vermont, and the Canadian provinces of Ontario and Québec. Although power was successfully restored to most customers within hours, some areas in the United States did not have power for two days and parts of Ontario experienced rotating blackouts for up to two weeks. The North American Electric Reliability Corporation (NERC) has developed and implemented a standing procedure for investigating future blackouts and system disturbances. The standing procedure requires that utilities monitor all tripping relays, circuit breakers, and teleprotection facilities that are classified as Bulk Electric Systems (BES). This standing procedure is required under NERC Reliability Standard PRC-002 Disturbance Monitoring Equipment (DME).

Modern digital protection and monitoring devices (IEDs) provide compliance with NERC DME standards; however upgrading legacy infrastructure with such IEDs is costly and time intensive. Legacy systems are analog-based and do not provide sufficient data for detailed analysis, and this limits the ability to determine root causes and mitigate risks of pending or actual failures. Most of the U.S. power grids including

nuclear power plants are analog-based, but NERC demands digital information for fault analysis and diagnosis. Accordingly, the digitization (monitoring) of legacy infrastructure is a focal point for both utilities and manufacturers although the analog system is reliable, has useful life, and is by nature not vulnerable to cyber-attacks. Often the driver for replacement is compliance with NERC DME Standards.

The current practice is to monitor legacy equipment through the use of existing spare output contacts. In most cases, limited quantities of output contacts are available and are primarily used for circuit breaker tripping. In the rare instance that spare output contacts do exist, a wire is connected from the output contact and marshaled to an existing or new IED. When spare contacts are not available, auxiliary devices with the needed output contacts are inserted into the existing control circuitry. In either case, the control circuitry is being modified/disturbed, which poses major challenges because of the risk of accidental actuation that may lead to an extensive loss of facility. The major challenges include, but are not limited to, scheduling outages to ensure that the control circuitry is initially 100% de-energized/isolated and fully tested for continuity to catch any potential wiring errors [3].

## II. INTRODUCTION

A Hall-Effect sensor is a device that detects the presence of a magnetic field. Magnetic fields occur when current is passed through a conductor. A voltage called the Hall voltage is generated when the sensor is placed perpendicular to both the current and magnetic field as seen in Figure-1 [1].

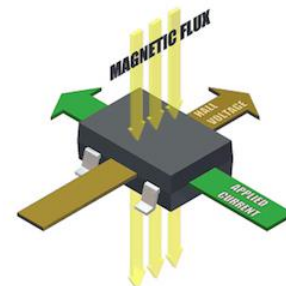

Figure-1: Hall Effect Sensor

When no magnetic field is applied to the current carrying thin semiconductor material (Hall element), the Hall voltage ( $V_h$ ) is zero. When an external perpendicular magnetic field is applied to the current carrying Hall element, a voltage is generated based on the Lorentz force, and acts on the current based on which the voltage is generated perpendicular to both the current and the magnetic field. This voltage is very small ( $\mu\text{V}$ ) and needs amplification for detection.

In its most common application, a Hall-Effect transducer serves to measure a magnetic field and convert that measurement into voltage. When an electric field exists in a metal it sets up an electric charge. This electric field exerts a force on the charge that makes a current move from one end of the conducting metal to the other. In the case of a conductor, when a current runs through from left to right producing positively charged carriers, the magnetic field pushes the positive charges toward the top edge of the cable and pushes the negative charges toward the bottom edge of the cable. Conversely, if the current is produced by negatively charged carriers, the magnetic field sends them in the opposite direction. In either case, a measurable electric field, called the Hall potential, is established between the two charged areas. And the sign of the potential difference between points on the top and bottom of the cable, known as the Hall-Effect, determines if the charge carriers are positive or negative.

In the semiconductor field, the Hall-Effect is most helpful in determining the appropriate polarity of semiconductor materials. The strength of the Hall potential also is proportional to the strength of the magnetic field applied to the conductor, which is known as a Hall Probe.

A change in the magnetic field around the Hall probe produces a corresponding change in the Hall potential [1]. A Hall-Effect transducer or sensor can measure both parameters, which includes the Hall potential and the strength of the magnetic field.

Many common applications rely on the Hall-Effect. For instance, some computer keyboards employ a small magnet and a Hall Probe to record when a key is pressed. Antilock brakes use Hall-Effect transducers to detect changes in a car wheel's angular velocity, which can then be used to calculate the appropriate braking pressure on each wheel. Hall Probes can also be used to measure very small and slow fluctuations in a magnetic field, down to a hundredth of a gauss.

### III. PROJECT DESCRIPTION

As a result of the August 14, 2003 blackout, the Regional Reliability Standard PRC-002-NPCC was developed to ensure that adequate disturbance data is available to facilitate Bulk Electric System event analyses [1].

#### A. Regional Reliability Standard Requirements

The standard requires that each Transmission Owner (TO) and Generator Owner (GO) provide Fault recording capability for the following Elements at facilities where Fault recording equipment is required to be installed [2]:

- All transmission lines
- Autotransformers or phase-shifters connected to buses
- Shunt capacitors, shunt reactors
- Individual generator line interconnections
- Dynamic VAR Devices
- HVDC terminals

Due to the fact that Consolidated Edison of New York (Con Edison) does not have Dynamic VAR Devices and HVDC terminals, this paper does not discuss the monitoring of these devices.

Each Transmission Owner and Generator Owner shall record for faults that are sufficient electrical quantities for the above mentioned elements to determine the following:

- Three phase-to-neutral voltages
- Three phase currents and neutral currents
- Polarizing currents and voltages, if used
- Frequency
- Real and reactive power

These requirements will ensure that today's modern day power systems are equipped with equipment that will provide adequate fault recording data to facilitate event analysis.

Fault records are one of the most important pieces of evidence that event analysts' can have during system event investigations. They can provide the reasons for premature equipment failure, supply waveforms and status of equipment behavior during an event, and give necessary information to perform post-fault event analysis. Proper use and interpretation of event records can lead to corrective action for a given system problem resulting in improved performance and reliability of any generation, transmission, and distribution system. Fault records are captured by microprocessor relays but the records are limited by sampling rate and record length. Some monitoring equipment use digital filters that do not reflect the real captured waveform. Digital fault recorders offer specialized, specific, and dedicated microprocessor equipment with far superior sampling rates, record lengths, and unfiltered recording abilities. Utility engineers have to make balanced decisions as to what equipment is better to use for pre- and post-event analysis.

#### B. Implementation Plan

Each Transmission Owner (TO) and Generator Owner (GO) are required to abide by the implementation plan generated by their regional entity. Con Edison is part of the geographic region that belongs to the Northeast Power Coordinating Council (NPCC) and therefore must abide to the implementation plan as it pertains to the Regional Reliability Standard PRC-002-NPCC. The effective dates of the PRC-002-NPCC standard are as follows [2]:

- 1) *Milestone #1: 50% Complete by 2<sup>nd</sup> Year*

- Install Sequence of Events (SOE) and Fault recording (FR) capabilities at 50% of the facilities that previously had no SOE and FR capability
- Install additional SOE and FR capability to facilities with existing capabilities such that 50% of the required capability is complete

### 2) Milestone #2: 75% Complete by 3<sup>rd</sup> Year

- Install SOE and FR capabilities at 75% of the facilities that previously had no SOE and FR capability
- Install additional SOE and FR capability to facilities with existing capabilities such that 75% of the required capability is complete

### 3) Milestone #3: 100% Complete

- Within four years of the FERC and Canadian entities approvals, all (100 percent) SOE and FR capability shall be installed to satisfy the requirements of the Regional Reliability Standard PRC-002-NPCC

Due to the expedited implementation plan, it has been extremely challenging to monitor all of the required analog traces. The Con Edison system has nearly 1,000 required analog traces to monitor and each of these analog traces require extensive system outages. To monitor each of the federally mandated required analog phases, Con Edison would have had to take one and a half outages per week for four consecutive years. This posed to be an issue as installation and testing resources were limited due to extensive system work previously scheduled. Additionally, during the summer months of May 15 through September 15, system outages are not scheduled and all work is dependent on system load and can cease at any time. To meet the implementation plan, the ECTs were used to eliminate the need to schedule and take hundreds of system outages. Through the use of these devices, Con Edison is on schedule to complete 100% of the required analog traces to be monitored.

#### C. The Electronic Current Transformer Installation

The federally mandated Reliability Standard PRC-002 requires that each of the Elements (described in the Project Description section above) have all phase and neutral currents monitored by a fault recorder. Monitoring of these required Elements would typically involve “disturbing” existing primary instrument current transformer circuits to install an auxiliary monitoring device (i.e. solid core current transformer). However, through the use of the new Electronic Current Transformer (ECT), monitoring of the required current phases was facilitated by requiring minimal installation and testing hours.

Con Edison’s 345kV Elements were subjected to the federally mandated Reliability Standard PRC-002 and were monitored by means of auxiliary monitoring devices (i.e. The Electronic Current Transformers, solid core CTs, and split core CTs). In locations where the ECTs were used, the phase and neutral currents were non-intrusively monitored. For the

three phase currents, the ECT sensors was installed in individual Element relay panels and were placed on the secondary leads of the primary instrument transformers on the internal side of the sliding link terminal blocks. To facilitate the installation process, standard drawings were developed to streamline the installation of each sensor.

Four sensors were placed onto the required cable to monitor and were held in place with the provided conductor stabilizer, a curved metallic shield and a wide temperature range tie wrap. Figure-2 depicts how the sensors are affixed to the green conductor.

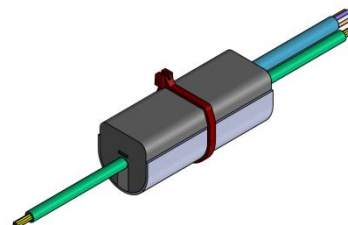

Figure-2: Sensor

Figure-3 and Figure-4 show the field installation of how the ECT sensors were non-intrusively installed onto the secondary leads of the primary instrument current transformer. The sensors were oriented on the cable in such a way that it points in the direction of current flow. This orientation represents the polarity of a standard CT and is visually represented by a yellow dot. The dot is at the head of each sensor to indicate polarity (this dot cannot be seen in the below figures).

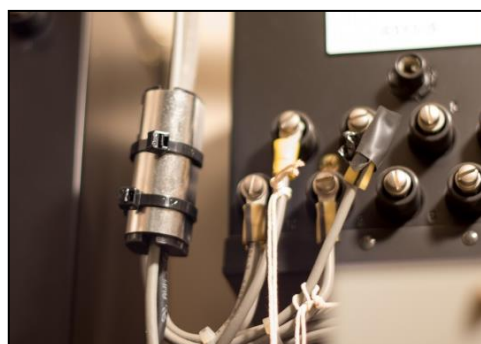

Figure-3: Field Installed A Phase ECT Sensor

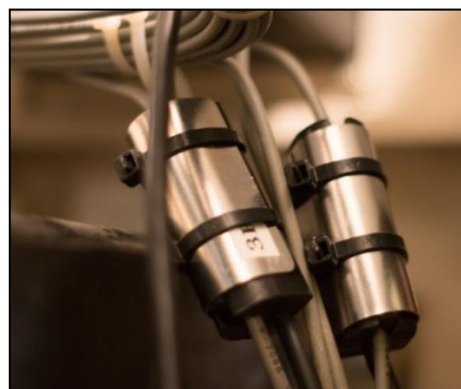

Figure-4: Field Installed B & C Phase ECT Sensors

Figure-5 shows an installation of a control module mounted onto a din-rail within a relay cabinet. The figure also shows how each of the four sensors are connected to the control module via quick connect connectors. The quick connect output signal cable is pre-terminated onto sliding link terminal blocks and marshalled to the digital fault recorder as an AC current value. Once at the DFR, each of the ECT signal cables were terminated into a voltage input of the DFR via a 12.5Ω resistor.

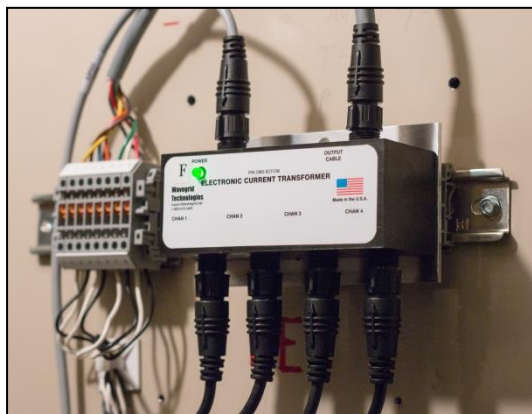

Figure-5: Field Installed Control Module

### 1) Transmission Line Monitoring

Each transmission line (voltage level of 345kV and above in Con Edison's case) is required to have each of its three phase currents and neutral current monitored. Throughout the Con Edison system, hundreds of transmission lines are subject to the monitoring requirement. To minimize installation efforts, the ECT was installed in select locations to non-intrusively monitor the required analog phases. Due to the non-intrusive nature of the ECT design, Con Edison field crews were able to install sensors on each of the required phases of the transmission lines without having to take the equipment out of service.

### 2) Autotransformer and Phase-Shifter Monitoring

#### Autotransformer Monitoring

The federally mandated Reliability Standard PRC-002 requires that each power transformer connected to buses have all three phase currents and neutral current monitored by a fault recorder.

In locations where the ECT was installed, the transformer high voltage side currents and neutral current were non-intrusively monitored. Due to the non-intrusive nature of the ECT design, Con Edison field crews were able to install sensors on each of the required phases of the power transformers without having to take the equipment out of service. This was extremely advantageous as the ECTs were generally used to monitor transformers at locations that are of a breaker and a half arrangement. These locations were

specifically chosen to eliminate the need to take the entire SYN-bus out of service to monitor the transformer.

#### Phase-Shifter Monitoring

Each of Con Edison's phase-shifters (Phase Angle Regulators) has had the source and load currents and the currents of the series and regulating windings monitored by the digital fault recorder. The ECT system (i.e. the module and four sensors) associated with each set of measured currents (i.e. Source, Load, Regulating Winding and Series Winding) were installed within the relay panel of the protective relaying devices to minimize wiring. Due to the non-intrusive nature of the ECT design, Con Edison field crews were able to install sensors on each of the required phases of the phase-shifter without having to take the equipment out of service. This was significant as these phase-shifters generally interconnect with neighboring utilities and therefore neither utility experienced time lost with the phase-shifter out of service.

### 3) Shunt Reactors

Each of Con Edison's shunt reactors has had each of its phase currents monitored by the digital fault recorder. The ECT system (i.e. the module and four sensors) associated with each set of measured currents were installed within the relay panel of the protective relaying devices to minimize wiring. Due to the non-intrusive nature of the ECT design, Con Edison field crews were able to install sensors on each of the required phases of the shunt reactor without having to take the equipment out of service. This was important as these shunt reactors can only be taken out of service during certain times of the year due to system loading and therefore monitoring these devices while in service provided a great deal of scheduling flexibility to system schedulers.

### 4) Generator Line Interconnections

The federally mandated Reliability Standard PRC-002 requires that generator line interconnections must have all three phase currents and neutral current monitored by a fault recorder.

In the single location where the ECT was installed, the generator interconnection had the three line phase and neutral currents non-intrusively monitored by the ECT. This installation was conducted while the generator remained in-service. This in-service work made this installation particularly important because the generator was not scheduled to be out of service for maintenance until after the Regional Reliability Standard completion date of October 20, 2015. In order to fulfill the standard, Con Edison would have required the generator to go off-line and hence would have incurred thousands of dollars of charges from the generator owner. Therefore, by the use of the ECT, Con Edison was able to not only save thousands of dollars of down generator time expenses but also meet the monitoring requirements for the generator line interconnection.



#### IV. TESTING

Extensive tests were performed to measure the accuracy of how the “Electronic Current Transformer (ECT)” responded to a range of steady-state and disturbance conditions. These tests included signature transient waveforms and actual Con Edison fault records to challenge how the ECT would perform within its design criteria. Additionally, these tests have been performed on various industry standard auxiliary current transformers to benchmark the performance of the ECT against these commonly used devices.

The test waveforms include a steady-state condition, DC components, and saturation signatures.

##### A. Test Composition

The tests comprise of COMTRADE files that were individually played back by a Power System Simulator (PSS) into a standard Digital Fault Recorder (DFR). These files were chosen to challenge each of the devices on how they respond to the PSS in magnitude and phase angle shift. For the purpose of this paper, the performed test cases discussed are as follows:

- A 40A RMS waveform
- Current Transformer Saturation (3 Phase Fault)
- Transformer Inrush
- Generator Interconnection (Actual Load Reading)

##### B. Test Equipment

- Digital Fault Recorder
- Power System Simulator
- Resistor: 10 $\Omega$  1W .01%

##### C. Test Software

- Universal Data Collection and Advanced Analysis
- Master Station (WINDFR and Remote software)

##### D. Tested Components

- Electronic Current Transformer: Model ECTCP-1 (modeled to a 1250:1 turns ratio)
- Solid Core Current Transformer: Model CTR-1001 (1000:1 turns ratio)

##### E. Test Configuration

- The PSS was connected directly into the DFR via the current inputs
- Four ECTs were non-intrusively mounted onto a 12AWG conductor utilizing the conductor stabilizers, shields, and environmental hardened wire ties
- Each of the four ECTs were connected to the Control Module via IP68 rated quick connect connectors
- The ECT module was powered by a 125VDC power supply and has its output cable (eight wires) connected directly to the DFR via 10 $\Omega$  resistors
- A 150A Solid Core CT was mounted onto the 12AWG conductor alongside the ECT

- The two secondary leads (signal and common) of the solid core current transformer were connected to the DFR via a 10 $\Omega$  resistor

Test setup configuration is seen in Figure 6 below.

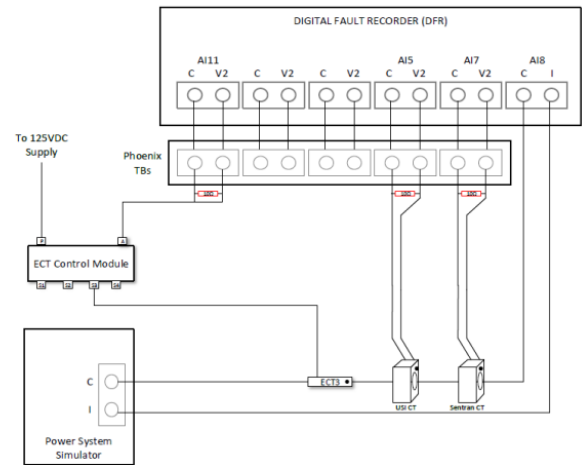

Figure-6: Test setup configuration

##### F. Test Cases

###### 1) Test Case 1: Magnitude and Angle

Test case 1 was designed to test how each of the current measuring devices perform under a steady-state 40A RMS signal. This test subjects the devices to a 40A RMS waveform with no offset and records their responsiveness. Channel 1 is the reference channel that each of the auxiliary devices are expected to emulate. Shown in Figure-7, it is apparent that under a steady-state condition each device accurately replicates channel 1.

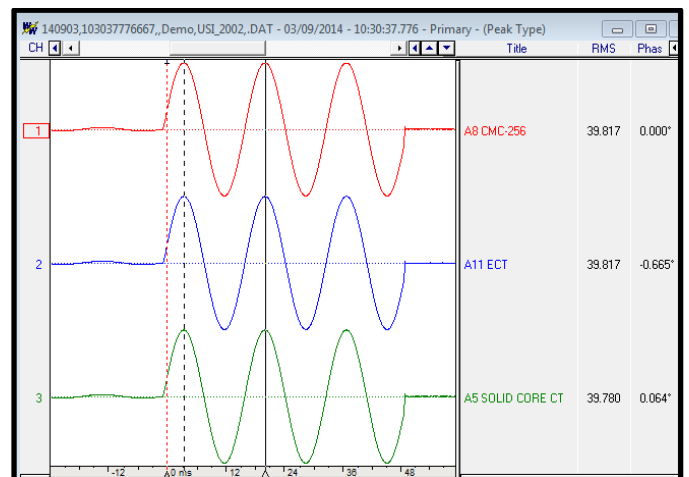

Figure-7: Magnitude and Phase Waveform Capture

To measure the accuracy of each device, a table was developed to organize the results. The below table (Table-A) compares the measured primary currents and phase angles of

the ECT and the solid core CT with the PSS. The performance of each device during a steady-state condition was tested to be excellent.

Table A: Test Case 1 Accuracy Results

Channel	Measured Primary Current (A)	Channel Accuracy (%)	Measured Phase Angle	Channel Accuracy (%)
PSS	39.817	---	---	---
ECT	39.817	0%	0.656	0.656%
Solid Core CT	39.78	0.09%	0.064	0.064%

In Figure-8 below, the ECT (color blue) and the solid core CT (color green) waveforms are super imposed on top of the PSS (color red) waveform. These waveforms mirror the PSS so well that only the color red is visible.

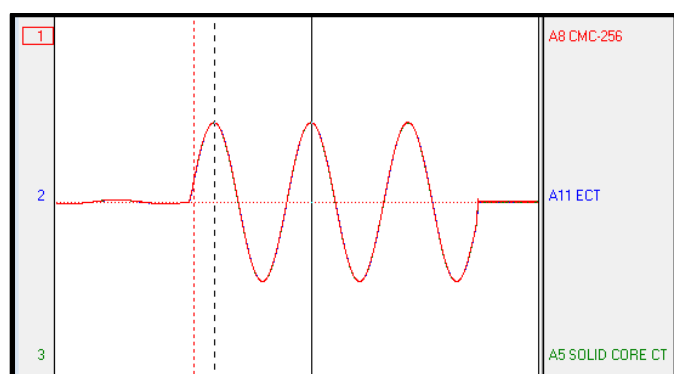

Figure 8: Magnitude and Phase Waveforms Super Imposed

## 2) Test Case 2: Current Transformer Saturation

Test case 2 was chosen to evaluate how each of the current measuring devices would respond to a saturated current transformer condition (three phase fault condition). The test file used for this test case was recorded by a microprocessor relay that was subjected to a three phase bus fault. This event saturated the primary current transformer and proved to be a valuable record to determine how the auxiliary current measuring devices would record this condition. The ideal situation would be that the auxiliary devices would emulate the primary current transformers secondary value within <1% in magnitude and <1% in phase shift. Figure-9 below represents the produced waveforms that each device produced as a result of the faulted condition. Channel 1 is the PSS and is the bench marking waveform that each of the other two devices is required to emulate. By quick inspection, it is clear that the ECT sensor did not saturate for this three phase fault condition.

To quantify the accuracy of each device, a table was developed to tabulate their results. Table-B below compares the measured primary currents and phase angles of the ECT and the solid core CT with the PSS. The data was measured approximately 3 cycles into the fault and documented for analysis. The results of the test show that the ECT is extremely

accurate even in cases where CT saturation is prevalent as it measured the fault current to within 44mA of the PSS while the solid core CT saturated and produced a current output difference of 9.41A of that of the PSS.

Table B: Test Case 2 Accuracy Results

Channel	Measured Primary Current (A)	Channel Accuracy (%)	Measured Phase Angle	Channel Accuracy (%)
PSS	20.763	---	---	---
ECT	20.719	0.212%	0.804	0.804%
Solid Core CT	11.351	45.33%	38.804	38.804%

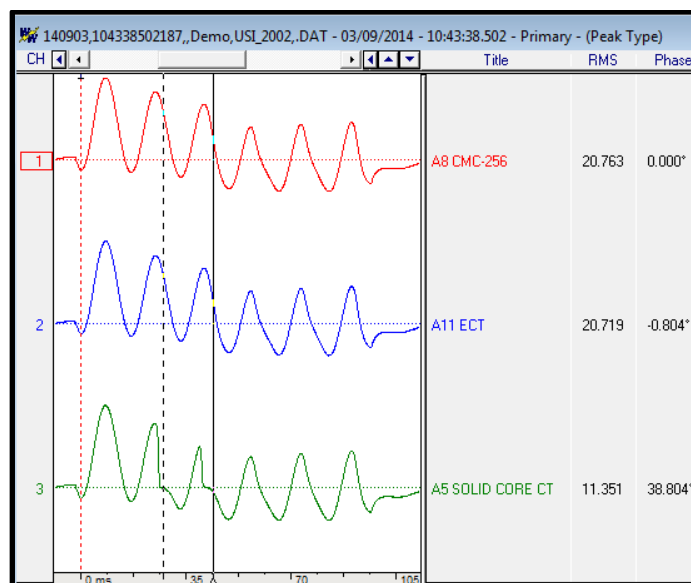

Figure 9: Inrush Waveform Capture

From Figure-10, the ECT and solid core CT waveforms are super imposed on top of the PSS waveform to depict magnitude and phase angle accuracy. This figure clearly shows that the waveform is nearly 100% offset and has a prominent DC component. Approximately at the second waveform peak, the solid core CT starts to saturate while the ECT continues to mirror the PSS (channel 1). This figure is a perfect example to see how the ECT is not susceptible to DC components and fully offset waveforms. By being impervious to the DC component phenomenon, the ECT does not saturate like traditional CTs and can accurately reproduce the primary currents to within .2% in magnitude and to within 1% in phase shift. This accurate reproduction is important as the DFR is provided with the true system condition and will not be subjected to a second degree of measurement errors.

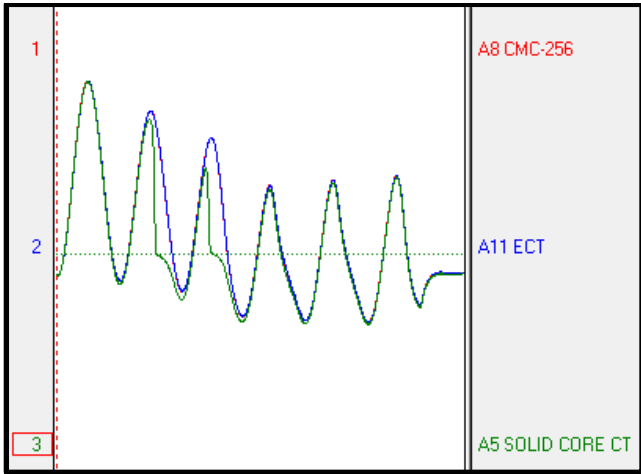

Figure 10: Inrush Waveforms Super Imposed

3) Test Case 3: Transformer Inrush: Fully Offset Condition

Test case 3 was chosen to evaluate how each of the auxiliary devices would respond to a fully offset condition. The test waveform was recorded by an Intelligent Electronic Device (IED) during a transformer energization. Figure-11 shows that the produced waveform is fully offset (for the first three cycles) transformer inrush waveform that lasts nearly 8 cycles.

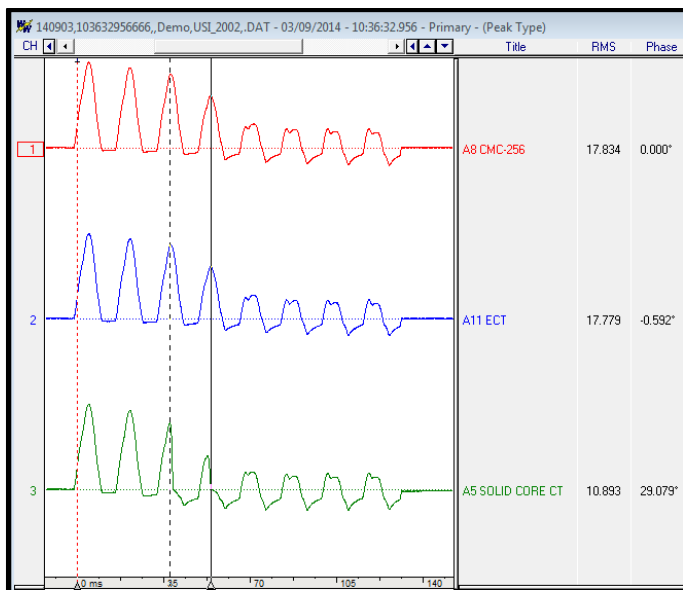

Figure 11: Transformer Inrush Waveform Capture

To quantify the accuracy of each device, a table was developed to tabulate their results. Table-C below compares the measured primary currents and phase angles of the ECT and the solid core CT with the PSS. The data was measured 4 cycles into the inrush phenomenon and documented for analysis. The results of the test show that the ECT is extremely accurate even in cases where a fully offset condition exists. The ECT measured the fault current to within 55mA of the PSS

while the solid core CT saturated and produced a current output difference of 6.941A of that of the PSS.

Table C: Test Case 3 Accuracy Results

Channel	Measured Primary Current (A)	Channel Accuracy (%)	Measured Phase Angle	Channel Accuracy (%)
PSS	17.834	---	---	---
ECT	17.779	0.31%	0.592	0.592%
Solid Core CT	10.893	38.9%	29.079	29.079%

From Figure-12, the ECT and solid core CT waveforms are super imposed on top of the PSS waveform to depict magnitude and phase angle accuracy. This figure clearly shows that the waveform is 100% offset and has a prominent DC component. It also shows that each device responds extremely well for the first 2 1/2 cycles until the solid core CT saturates nearly at the peak of the third cycle. The solid core CT takes almost four additional cycles before it recovers while the ECT does not saturate and emulates the PSS throughout the entire waveform.

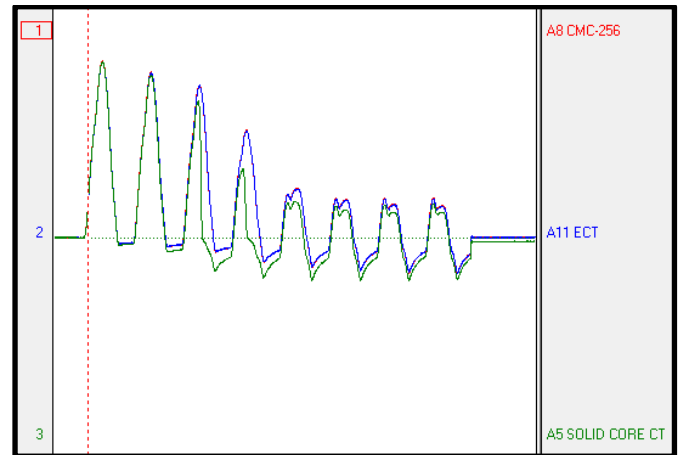

Figure 12: Transformer Inrush Waveforms Super Imposed

4) Generator Interconnect (Actual Load Reading)

Con Edison is required to monitor each of its 345kV generator interconnections to meet the Regional Reliability Standard PRC-002-NPCC. To do this, both Con Edison and the generator owner must agree to take the generator out of service. One of the generator interconnections on the Con Edison system was not scheduled to be taken off-line for maintenance until after the reliability standard was required to be completed. Due to this, Con Edison would have incurred a penalty to take the generator off-line to install all required DME monitoring capabilities. However, through the use of the ECT sensors Con Edison field personnel were able to non-intrusively monitor all required analog traces while the generator remained in service. In fact, the field crew was able to completely monitor each of the 345kV feeder phases within

an hour and no additional testing was required as existing circuits were not modified.

To assure that the sensors were accurately reproducing the generators load current, analog meters were used to measure the secondary currents seen by the protection devices. These measurements and the values measured by the DME are shown in Table-D below and the waveform traces are shown in Figure-13. It can be seen that the ECT sensors are reproducing the generator load currents to within 0.6% of the measured values.

Table D: DME Verified ECT Accuracy

Channel	Measured Secondary Current (A)	Calculated Primary Current (A)	DME Primary Current (A)	Channel Accuracy (%)
A Phase	2.77	1108.00	1101.39	0.596
B Phase	2.665	1065.20	1065.65	0.043
C Phase	2.58	1032.00	1028.01	0.386

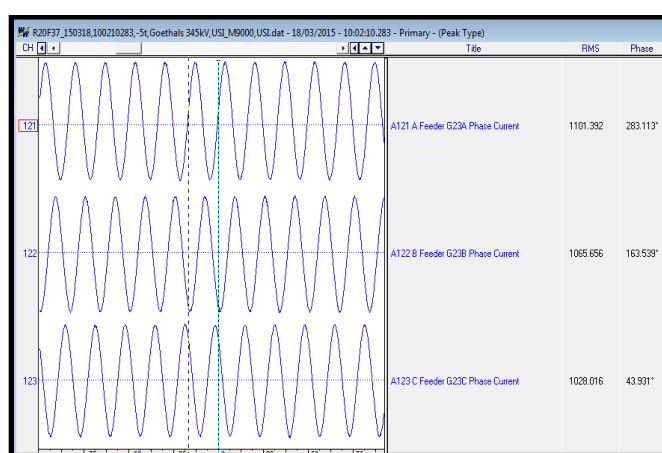

Figure 13: Generator Interconnection Load Reading

## V. ADVANTAGES

### A. Cost Savings

Due to the non-intrusive nature of these sensors (sensors do not disturb existing circuits) the following cost requirements were eliminated:

- Costs associated with equipment taken out of service
- Man-hours associated with breaking into existing circuits to install auxiliary current transformers.
- Man-hours associated with field testing of disturbed circuitry
- Man-hours associated with planning, scheduling, reviewing, removing and restoring the affected equipment
- Engineering drawing packages were scaled down by not requiring “removal” packages and by developing standard installation drawings

A cost comparison was conducted to determine the cost savings between a traditional analog trace installations and the

newly proposed non-intrusive method and it was determined that the non-intrusive method can have savings potential that exceeds 80% of a traditional installation.

Table-B compares the installation and circuit testing hours between a typical (intrusive) monitoring design and the new non-intrusive monitoring solution. The hours stated are for the monitoring of four analog phases (A, B, C and N).

Table E: Installation Hours (Typical vs. Non-Intrusive)

Typical Auxiliary Devices		The Electronic Current Transformer	
	Hours / 4 CTs		Hours / 4 ECTs
<b>System Testing Hours</b>		<b>System Testing Hours</b>	
* Panel Isolation	2	* Panel Isolation	0
* Wire checks	8	* Wire checks	0
<b>Total Testing Hours:</b>	<b>10</b>	<b>Total Testing Hours:</b>	<b>0</b>
<b>Installation Hours</b>		<b>Installation Hours</b>	
* Removal of existing cable	3	* Mount and Power Module	1.5
* Installing of auxiliary CTs (4)	5	* Mount sensors (4) to cable	1
* Installing FT-1 Switches and TBs	1	* Installing FT-1 Switches and TBs	0
* Marshal CT cables to DME	1	* Marshal module cable to DME	1
<b>Total Installation Hours:</b>	<b>10</b>	<b>Total Installation Hours:</b>	<b>3.5</b>
<b>Total Hours:</b>	<b>20</b>	<b>Total Hours:</b>	<b>3.5</b>

### B. Standardization

Extensive efforts have been made throughout Con Edison’s engineering teams to ensure that engineering processes are efficient and cost effective. Through the use of the ECT, existing circuits are not disturbed and therefore it has been realized that a standard means of installing each sensor has led to the standardization of engineering design drawing packages.

Template drawing packages were developed to monitor each of the required elements. These template drawings were used as “typical” drawings to train and discuss the installation process with various engineering teams and field personnel. These discussions vetted out all potential installation issues and allowed for the field crews to actively participate in the installation design well in advance of the installation date. The non-intrusive nature of the ECTs allowed for fewer drawings (elimination of disconnect drawings) to be modified and the elimination of changes to the existing internal point-to-point wiring diagrams and documentation. Overall, the amounts of drawings were reduced by nearly 70%, the engineering drawing review process was streamlined, and human performance was improved.

## VI. CONCLUSIONS

This paper presented a number of test cases where the Electronic Current Transformer proved to be a viable means of meeting the NERC Regional Reliability Standard PRC-002-NPCC-Disturbance Monitoring requirements. The case studies used actual fault records to prove that the non-intrusiveness of



the Electronic Current Transformer either meets and or exceeds the performance of typical industry standard intrusive devices.

The sensors are non-intrusive, inexpensive and can be deployed in a timely manner without having to remove equipment from service. The non-intrusive design allows the existing circuitry not to be disturbed, and therefore eliminates the requirements to retest circuits. Without having to disturb circuits the costs associated with installations (i.e. disconnect and reconnect) are minimized. The intangible cost savings (elimination of outages, elimination of possible rewiring mistakes, incorrect equipment isolation, reduction of scheduling resources, etc.) have proved to be priceless.

Through the use of non-intrusive Intelligent Electronic Sensors, utilities have an alternative means of meeting the NERC Regional Reliability Standard PRC-002-NPCC-Disturbance Monitoring requirements at a reduced cost. Each of the monitoring requirements can be satisfied all while achieving the following benefits:

- Excellent accuracy and performance
- Flexibility of installation and removal
- Significantly decrease installation time
- Elimination of system outages
- Eliminate the need of scheduling resources
- Eliminate the need to disturb existing circuitry
  - Eliminate the possibility of wiring errors
  - Eliminate circuit testing costs
  - Eliminate possibility of isolation errors
- Eliminate the burden on the primary current transformer
- Develop standard design templates that can reduce the required number of engineering drawings and streamline the engineering review process

#### AUTHOR BIOGRAPHY

Don Burkart is a relay protection engineer with Consolidated Edison of New York, Inc. in New York, New York. Don received his BSEE degree at New York Institute of Technology and earned his MSEE degree with emphasis in Power Systems at Polytechnic University of NYU. He is a Senior Member of IEEE and actively participates in the New York Chapter.

#### REFERENCES

- [1] L. J. Blackburn, *Protective Relaying Principles and Applications*, New York: Marcel Dekker, Inc, 1998.
- [2] NPCC Regional Reliability Standard, *Standard PRC-002-NPCC-1-Disturbance Monitoring*, 2010.
- [3] D. C. Burkart, How the Use of Non-Intrusive Sensors Facilitate NERCs Regional Reliability Standard PRC-002-NPCC-Disturbance Monitoring, Georgia Tech Fault Disturbance Conference, 2014